

P&M[®] **AJ52**

Slim-line Sliding Door System
– with soft close mechanism

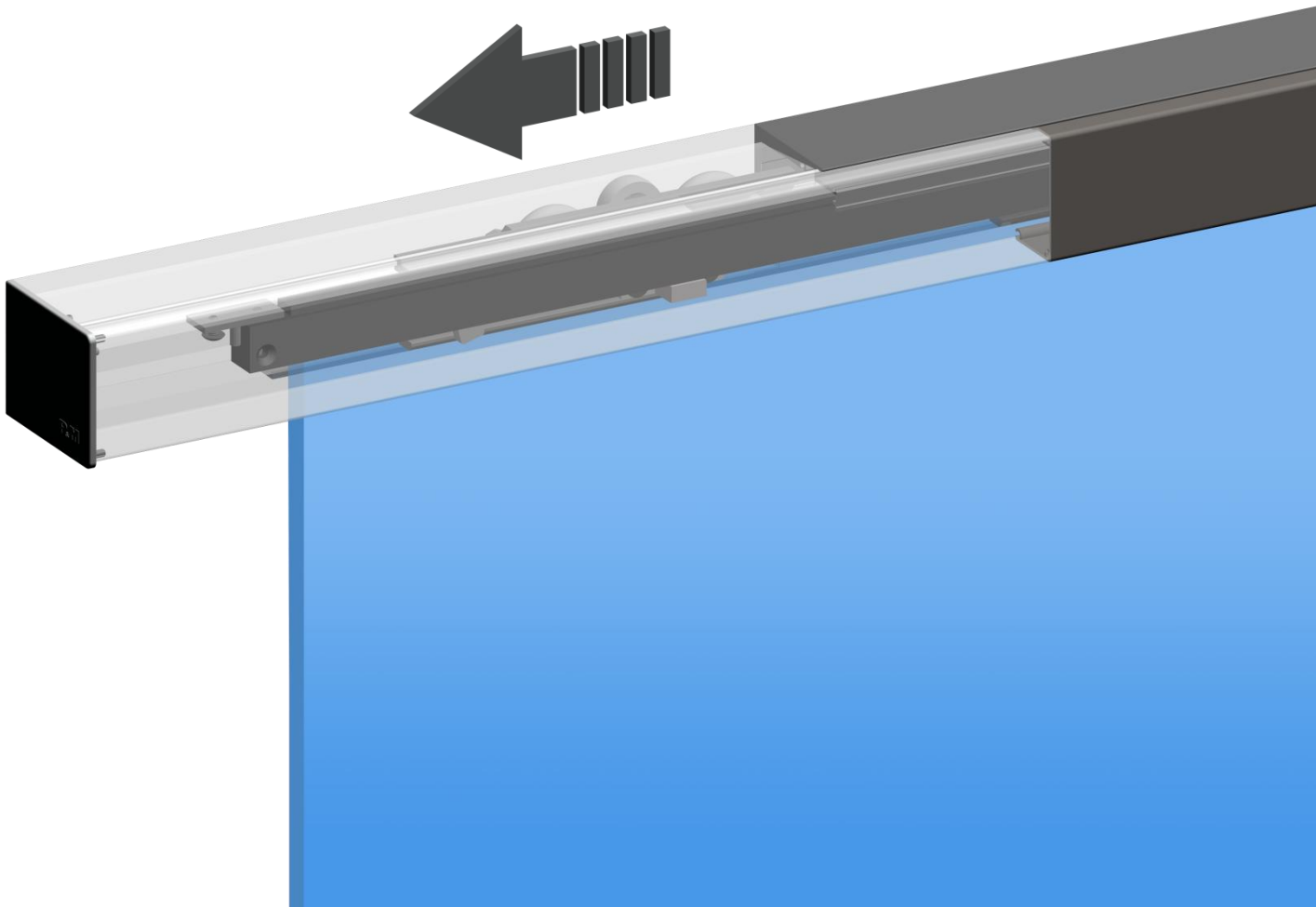

P&M AJ52 Slim-line Sliding Door System is aesthetic, sturdy and versatile in both construction and design.

The sightline is only 51mm comprising of a single piece extruded aluminium track with a clip-on cover and end caps at both ends. Both the track and cover are available in brushed satin, polished anodised and natural anodised finishes. Three independent rollers attached to the clamps, facilitate a smooth rolling motion and prevent the clamp assembly from jumping off the track. Hydraulic damper within the track operates as soft closing mechanism.

The system can be wall mounted , ceiling mounted and mounted to side and over glass panels. Efficient clamping and rollers system allows AJ52 to carry a maximum weight of 80 kg per glass panel and maximum glass thickness of 13.52mm.

AJ52 is efficient and economical. There is no need for any glass clamping notch preparation. Coupled with its slim sightline, AJ52 is a choice for every designers and installers.

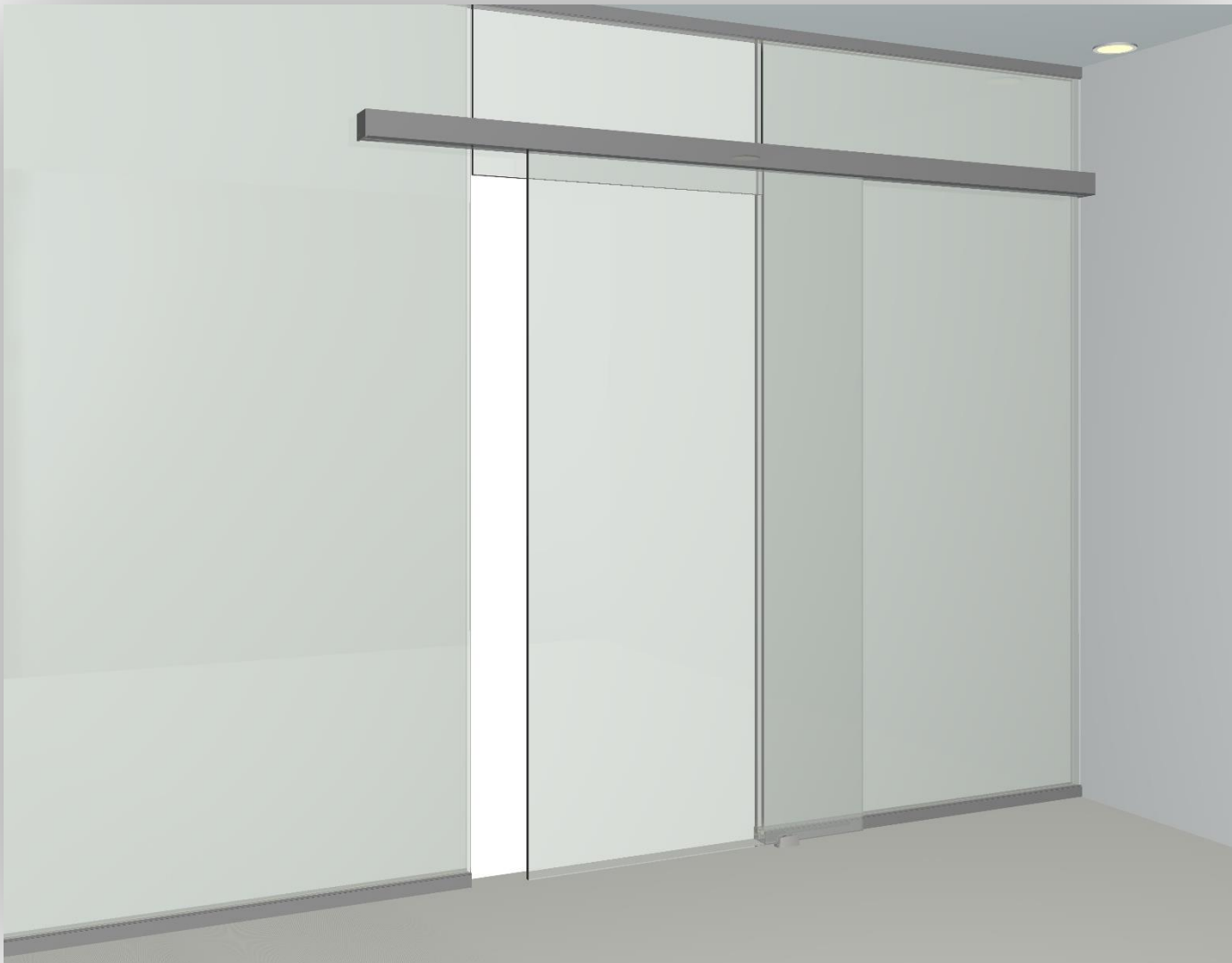

AJ52 Overpanel and Side Panel Mounted Sliding Door System

Components

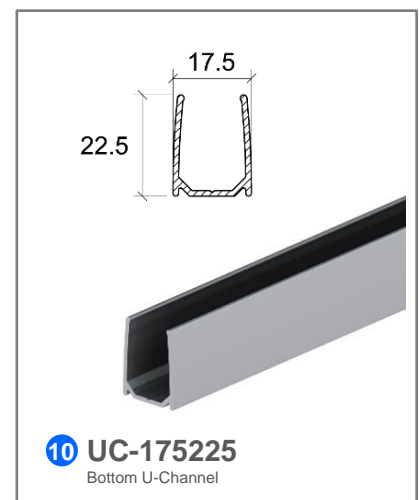
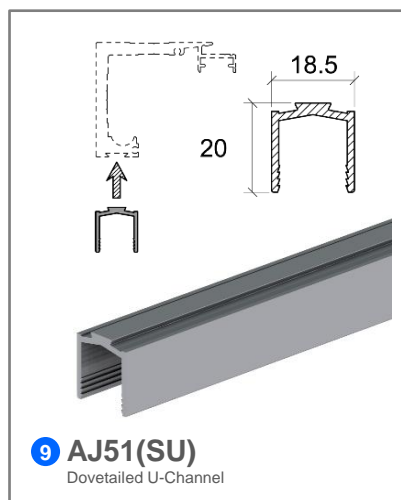
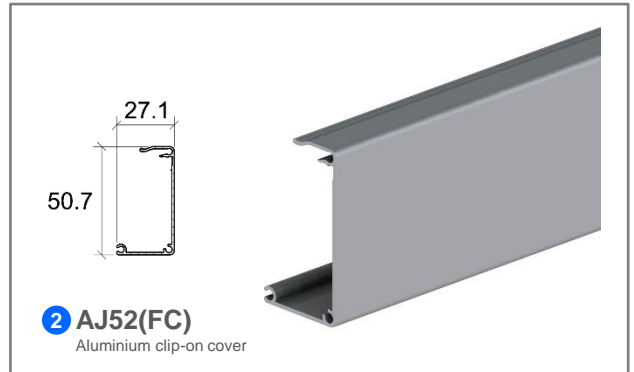
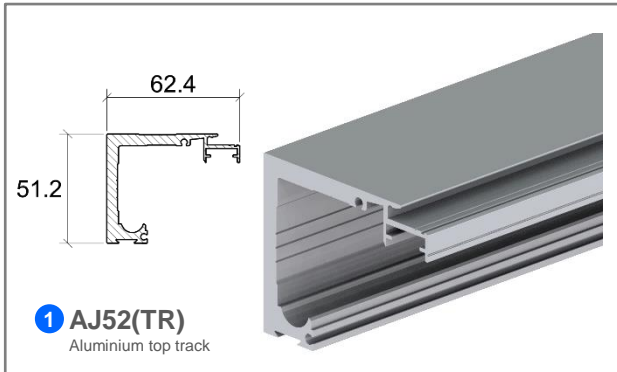

Wall Mounted Sliding Door System

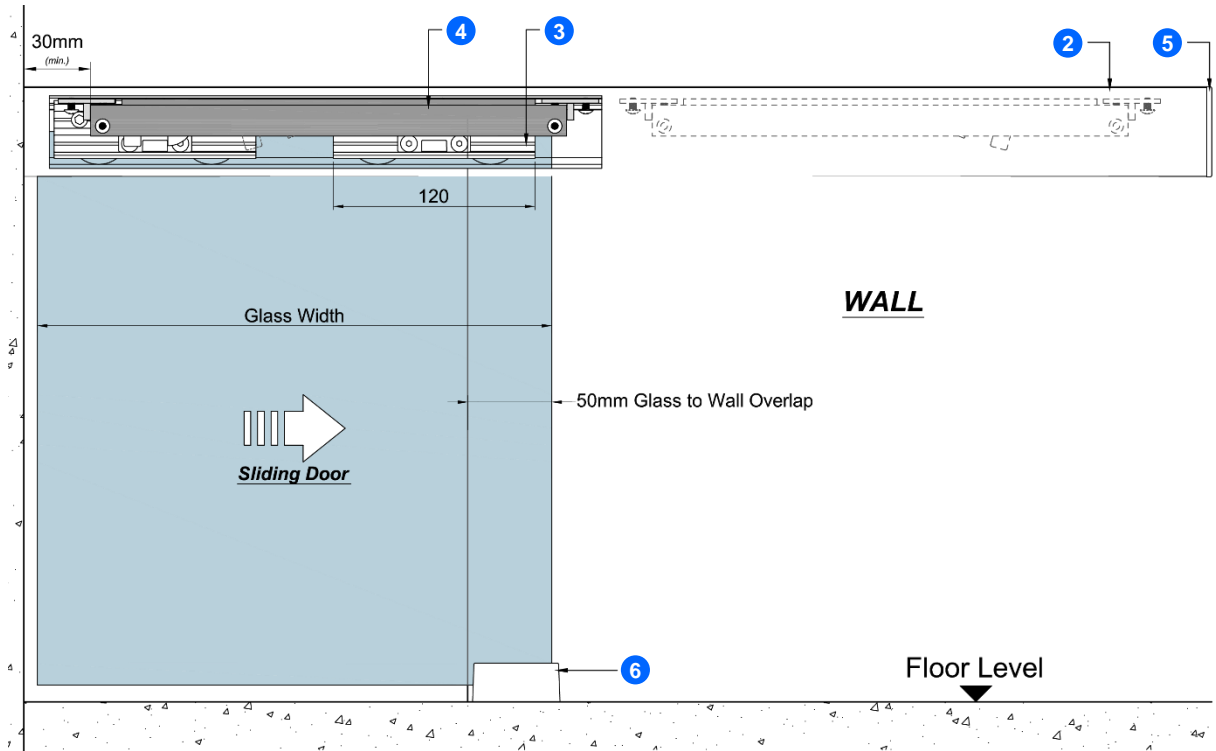

AJ52 Wall Mounted Sliding Door System

is available with the following standard components as a complete system:

- 1 AJ52(TR) Aluminium top track
- 2 AJ52(FC) Clip-on aluminium cover
- 3 AJ52(CR3) Three wheels carriage rollers glass clamp with hook
- 4 HY-72 Hydraulic damper
- 5 AJ52(EC) End cap (LH&RH)
- 6 UG-ALT4 Single-U stainless steel floor guide
- 8 AJ52(CP) Aluminium cover piece

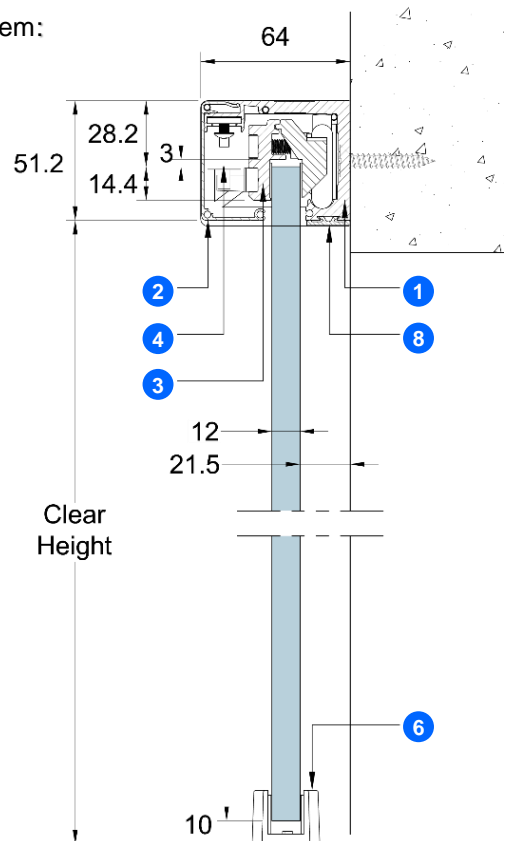

AJ52 Ceiling Mounted Sliding Door System

is available with the following standard components as a complete system:

- 1 AJ52(TR) Aluminium top track
- 2 AJ52(FC) Clip-on aluminium cover
- 3 AJ52(CR3) Three wheels carriage rollers glass clamp with hook
- 4 HY-72 Hydraulic damper
- 5 AJ52(EC) End cap (LH&RH)
- 6 UG-ALT4 Single-U stainless steel floor guide

Ceiling Mount with

Fixed Glass Panel Below Track

- 9 AJ51(SU) Dovetailed U-channel
- 10 UC-175225 Bottom U-channel

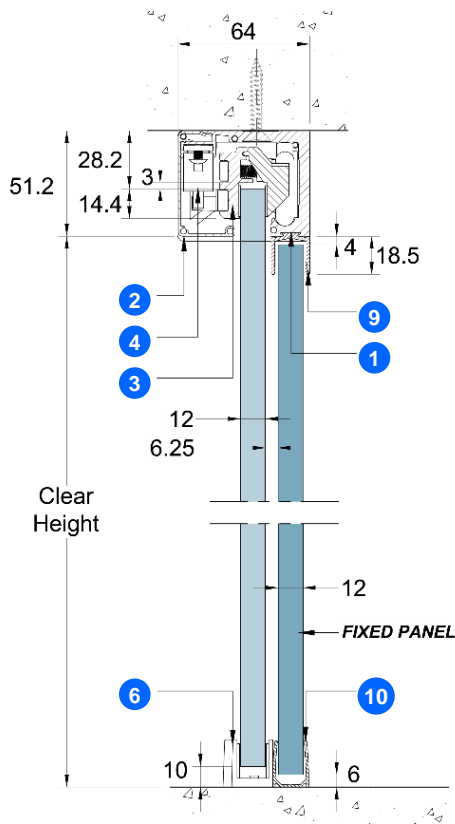

Ceiling Mount with

Fixed Glass Panel Behind Track

- 7 AJ51-TTG30 Track to glass connector
- 8 AJ52(CP) Aluminium cover piece
- 10 UC-175225 Bottom U-channel

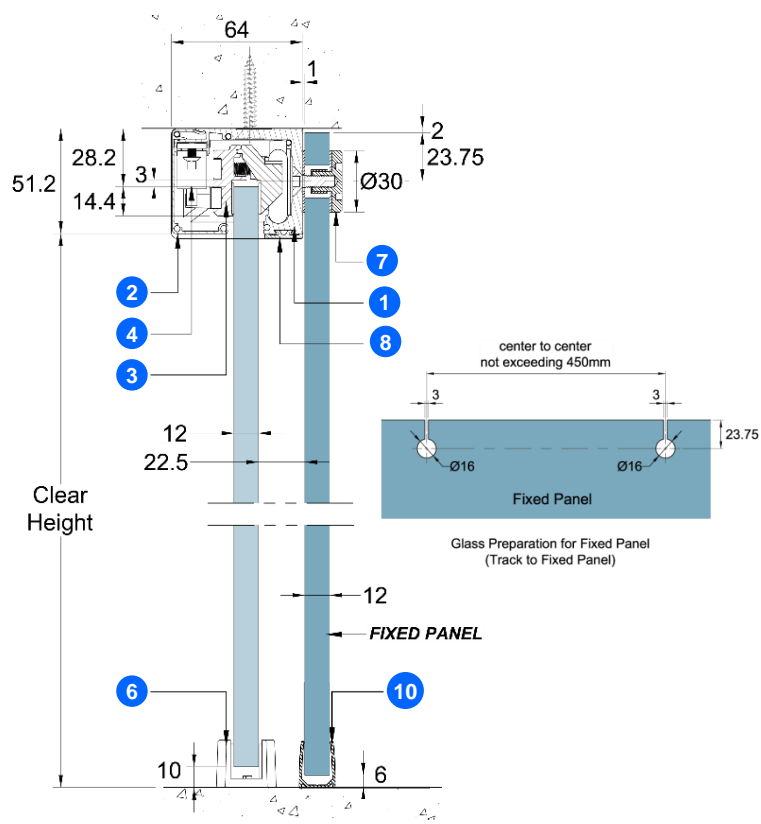

AJ52 Overpanel and Side Panel Mounted Sliding Door System

is available with the following standard components as a complete system:

- 1 AJ52(TR) Aluminium top track
- 2 AJ52(FC) Clip-on aluminium cover
- 3 AJ52(CR3) Three wheels carriage rollers glass clamp with hook
- 4 HY-72 Hydraulic damper
- 6 UG-ALT4 Single-U stainless steel floor guide
- 7 AJ51-TTG30 Track to glass connector
- 8 AJ52(CP) Aluminium cover piece
- 10 UC-175225 Bottom U-channel

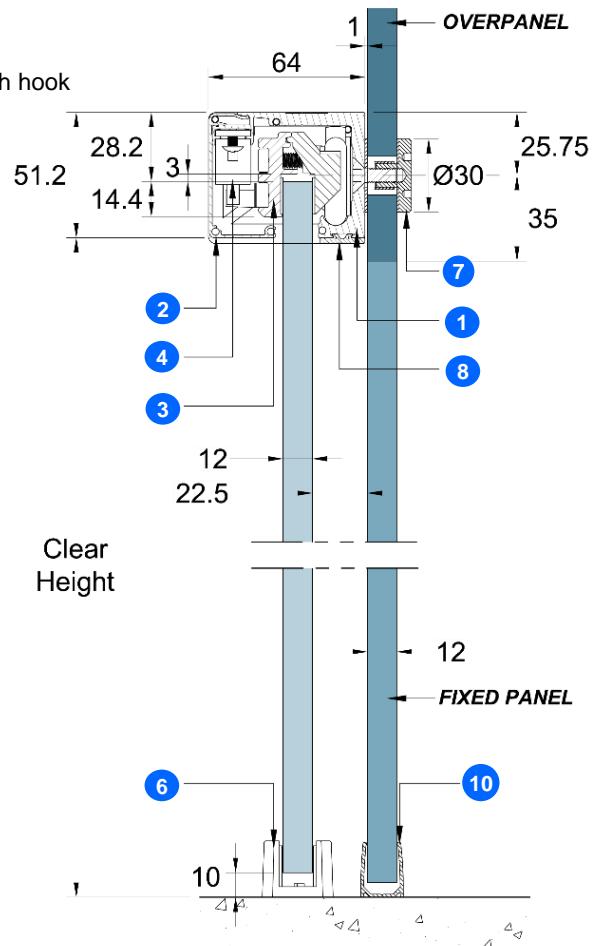

Typical Glass Elevation

Single Leaf Door Mounted to Overpanel and Fixed Panel

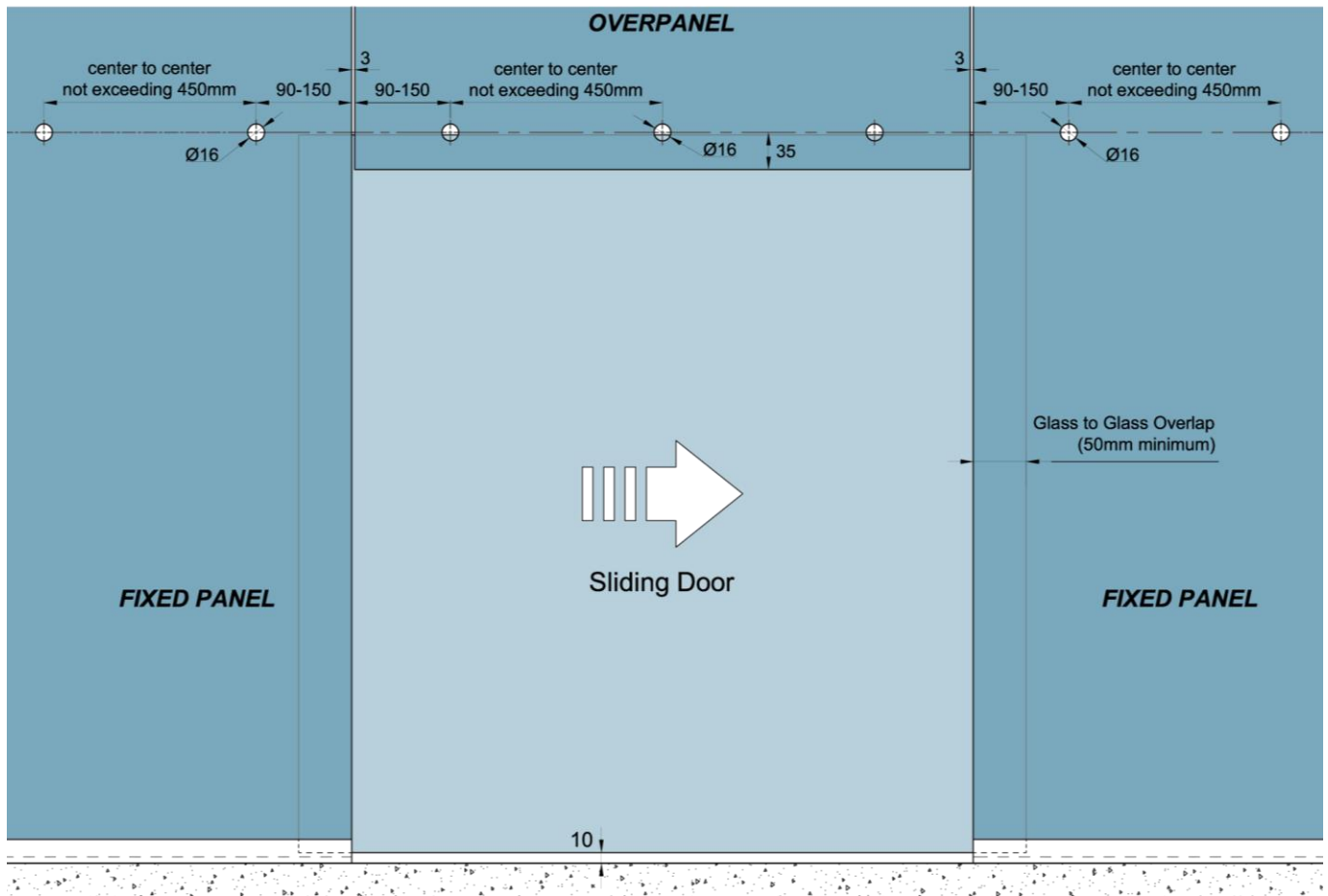

Door Specification

Minimum Door Width : 600 mm W
Maximum Door Width : 1000mmW
Maximum Door Height : 2700mmH
Maximum Door Weight : 80kg
Glass Thickness: 8 – 13.52mm

Note:

Kindly consult our technical advise if panels exceeds stated dimension.
Subject to technical consideration if exceed on the maximum door specifications

● **Profile Finish:**

- Natural Anodised Aluminium
- Bright Anodised Aluminium
- Brushed Satin Aluminium

Due to the company's policy of continuous product development and enhancement, the specifications and details contained in this brochure are subject to alteration without prior notice.

The dimensions, details, specifications and statements made herein or by our representatives arising out of any enquiries are given for information purposes only. They are not intended to have any legal effect and the company will not be bound thereby. The company will only accept obligations which are expressly negotiated for, and agreed and incorporated into written agreements made specifically with its respective customers.

Related Products



Door Handles – Melosa Series



Door Knobs – Cerise Series

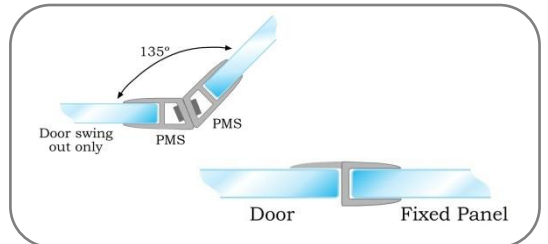

Vinyl Clip Seals – Deane Series



Preference Pte Ltd

No.2 Kallang Pudding Road #01-02 Mactech Building Singapore 349307

Tel: (65) 6746 5185 Fax: (65) 6746 8749 Email: enquiry@preference.com.sg Website: www.preference.com.sg