



CR311



CR312

Wall Mounted Hinge *for Interior Glass Door*

CR311 & CR312

Glass Hinge

- Suitable for 8 to 12mm thick glass
- SUS304
- Satin Stainless Steel Finish
- Maximum door weight: 60kg per 2 hinges
- Maximum door width: 900mm

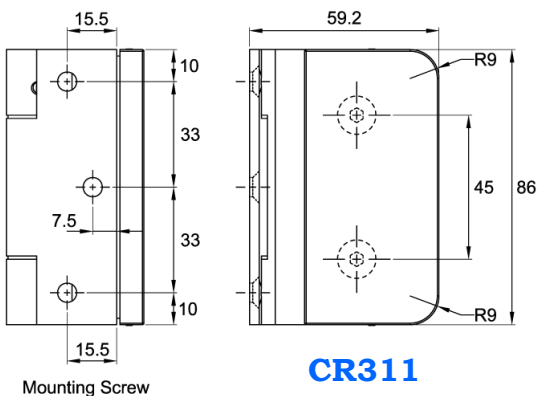
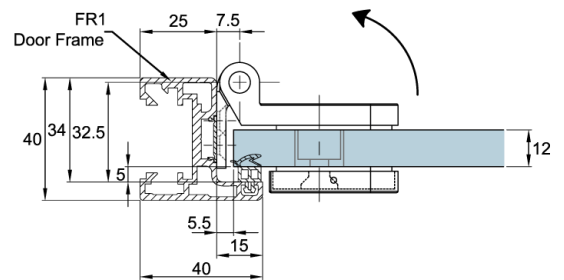
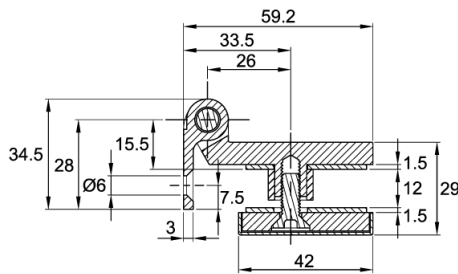
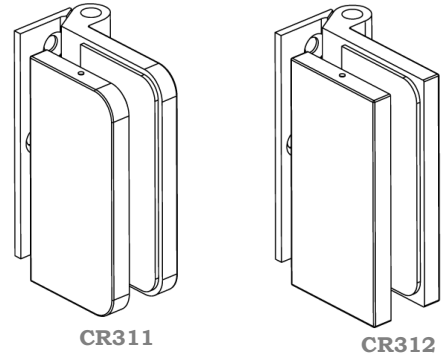

CR311

Mounting Screw

Glass Preparation

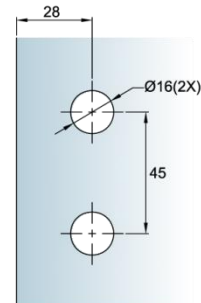

Due to the company's policy of continuous product development and enhancement, the specifications and details contained in this brochure are subject to alteration without prior notice.

The dimensions, details, specifications and statements made herein or by our representatives arising out of any enquiries are given for information purposes only. They are not intended to have any legal effect and the company will not be bound thereby. The company will only accept obligations which are expressly negotiated for, and agreed and incorporated into written agreements made specifically with its respective customers.



Preference Pte Ltd

No.2 Kallang Pudding Road #01-02 Mactech Building Singapore 349307

Tel: (65) 6746 5185 Fax: (65) 6746 8749 Email: enquiry@preference.com.sg Website: www.preference.com.sg