

HR101 Hinge with DB1 Frame Pivot

- Material: SUS304
- Satin Stainless Steel finish
- Maximum weight: 60 kg per 2 hinges
- Suitable for 10 to 13.52mm glass thickness

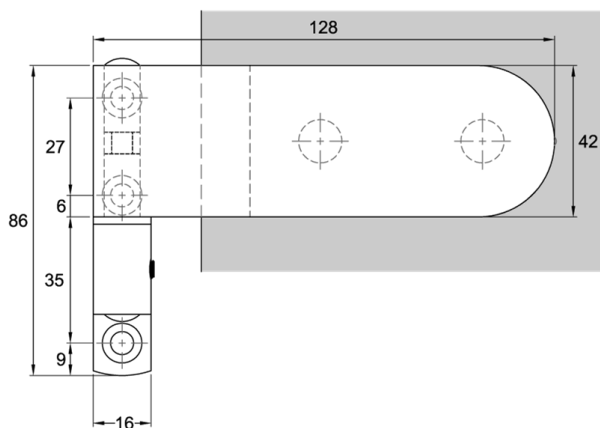

HR101 Glass Preparation

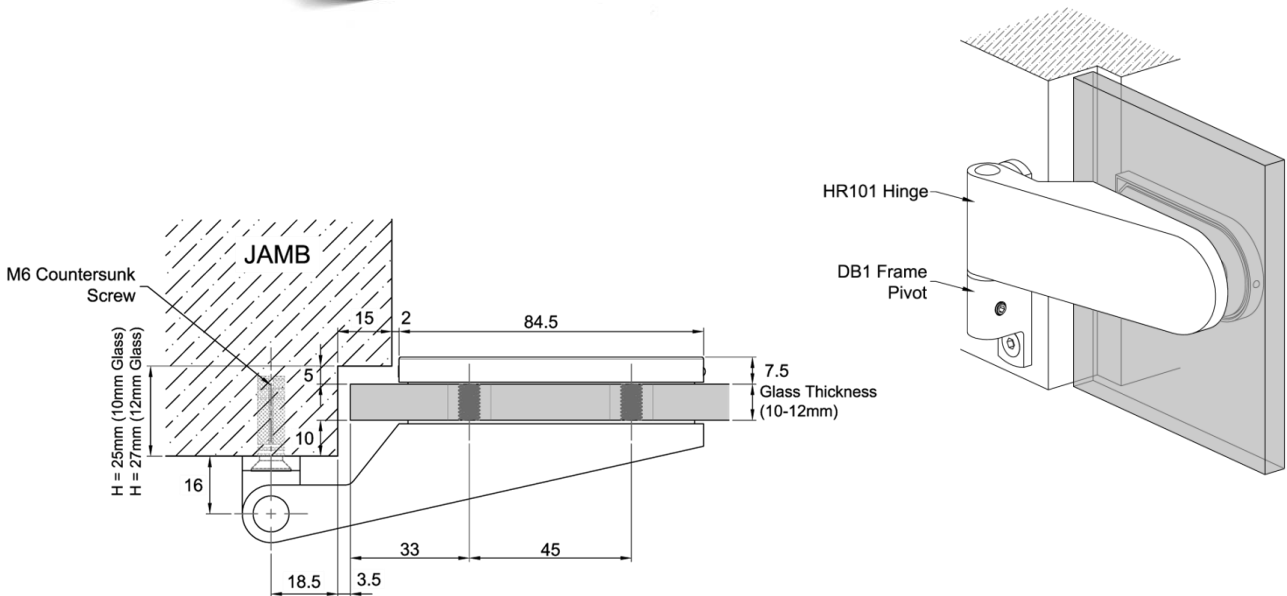
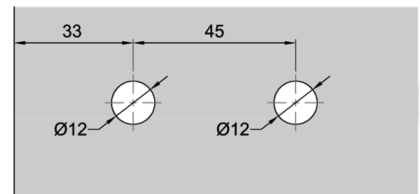

HR101 Hinge with DB2 Offset Frame Pivot

- Material: SUS304
- Satin Stainless Steel finish
- Maximum weight: 60 kg per 2 hinges
- Suitable for 10 to 13.52mm glass thickness

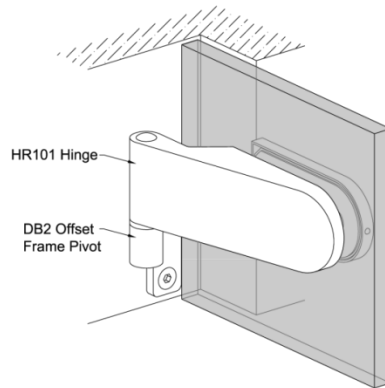
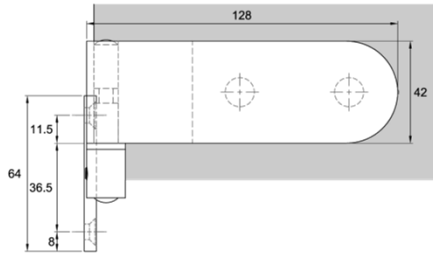
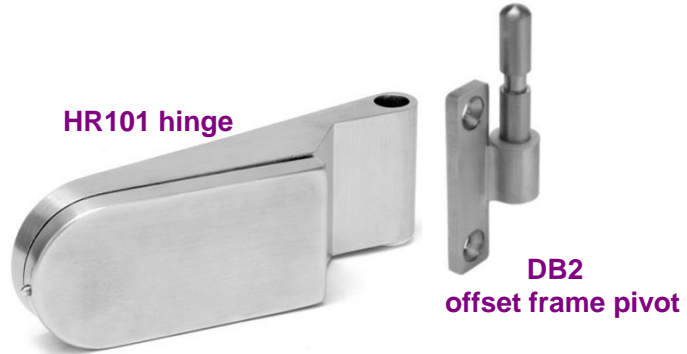
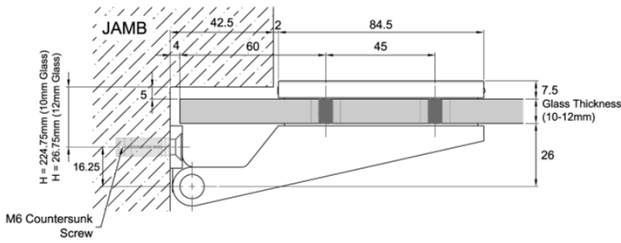

HR101 Hinge with DB3 Frame Pivot

